

SUPERBOND[®]

FUNCTION • QUALITY • DESIGN

LEADING EDGES

GOLD EDITION

QUALITY DESIGN

A Step Up in Design & Durability

SUPER BOND offers inspiration on a grand scale. With a brand new collection of Textured, Metallic and Solid, Sand, Wood, Chameleon panels SUPER BOND assures that the toughness of its products stay uncompromised.

National Reach & Unrivalled Service

The high-tech plant at Palghar, Maharashtra has a natural edge over the competition by being closest and fastest to market.

Hundreds of satisfied customers validate the distinguishable experience of choosing SUPER BOND - Unmatched Services!

BUSINESS EXPERTISE

After years of hard work and persistence, SUPER BOND has established itself as a trustworthy and a sound player in the industry. The company produces impeccable quality panels in a world class manufacturing unit that is operated and supervised by the finest personnel in the industry.

SUPER BOND can furnish composite panels upto 1550mm width. The company also prides itself in providing customization on almost all specifications of composite panels. This success is a result of diligence and expertise of the management and the production team.

With clarity in vision and resolute mission, SUPER BOND is set to lead the industry standards.



THE INDUSTRY STORY

The top and the bottom layers of ACP are of coated aluminium coils and the core sandwiched between them is polyethylene.

- Protection Film with Company logo
- Primer Coating (used in case of PVDF Only)
- Adhesive Film
- Adhesive Film
- Service Coating (Anti-corrosive)
- PVDF/Polyester Resin Based Coating
- Chromate Treated Aluminium Coil
- Polyethylene Core (LDPE)
- Aluminium Coil

STANDARD PANEL DIMENSIONS

Thickness: 3mm, 4mm, and 6mm as per requirement.

Special thickness & length available on request.

Std size: 1220mm x 2440mm, 1220mm x 3050mm, 1220mm x 3660mm

Other width: 1550mm x 915mm (as per requirement)

Product tolerance	Width	Length	Thickness		Squareness Maximum 5.0 mm	Bow Maximum 0.5 % of width and / or length
			Coil	Panel		
	+ 2.0 mm	+ 4.0 mm	+0.03mm	+0.2 mm		

PRODUCT CHART

Grades	Panel Thickness	Top Coil	LDPE Core Thickness	Bottom Coil	Top Coil Coating Thickness	Bottom Coil Coating Thickness	Use/ Warranty
SB Gold 1	4.00 mm	0.50 mm	3.00 mm	0.50 mm	26 μ + 2	12 μ + 2	Exterior/10 years
SB Gold 2	4.00 mm	0.25 mm	3.50 mm	0.25 mm	26 μ + 2	12 μ + 2	Exterior/10 years
SB Gold 3	3.00 mm	0.25 mm	2.50 mm	0.25 mm	26 μ + 2	12 μ + 2	Exterior/10 years
Excel	3.00 mm	0.15 mm	2.70 mm	0.15 mm	16 μ + 2	10 μ + 2	Exterior/05 years

ALUMINIUM COIL USED ARE OF ALLOYS 3003 - H 16 AND 1100 ALLOY H16

To avoid possible color differences, all the panels must be installed in the same direction as indicated by the arrows on the protective film. Different batches of products may have a color difference, so we recommend that you place a one-times order for each project to ensure that the color is same.

Note: Custom Colors & Grades Can be Produced

SOLIDS SERIES

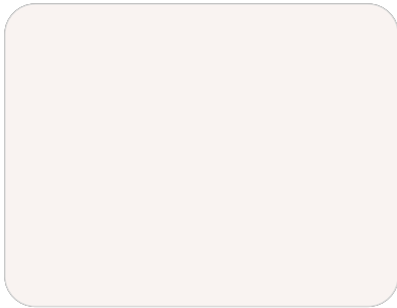

◆◆◆◆ SB503 | MILKY WHITE

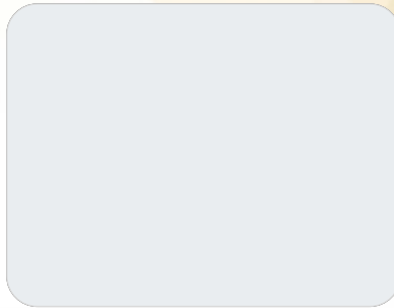

◆◆◆◆ SB131 | BRIGHT WHITE

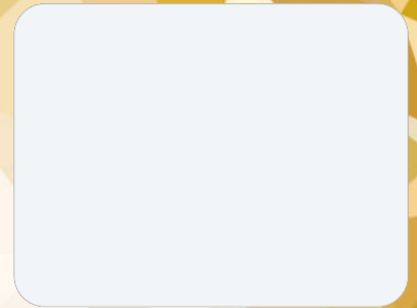

◆◆◆◆ SB130 | SUPER WHITE



◆◆ SB373 | BURGUNDY



◆◆◆◆ SB243 | INDIAN RED



◆◆◆ SB331 | GARNET ORANGE



◆◆◆ SB232 | TRAFFIC YELLOW



◆◆◆ SB231 | LEMON YELLOW



◆◆◆ SB323 | EMERALD GREEN

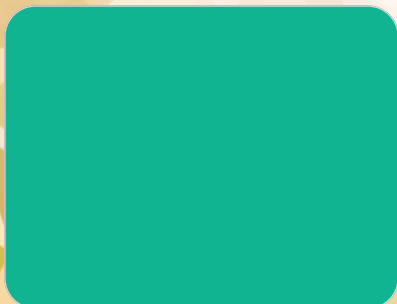

◆◆ SB420 | GRASS GREEN



◆◆◆◆ SB113 | OFF WHITE

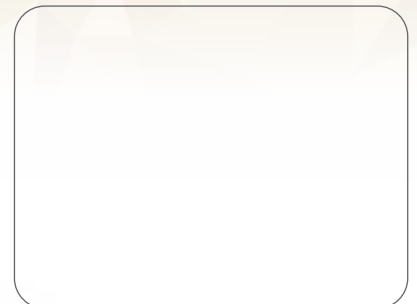

◆◆ SB261

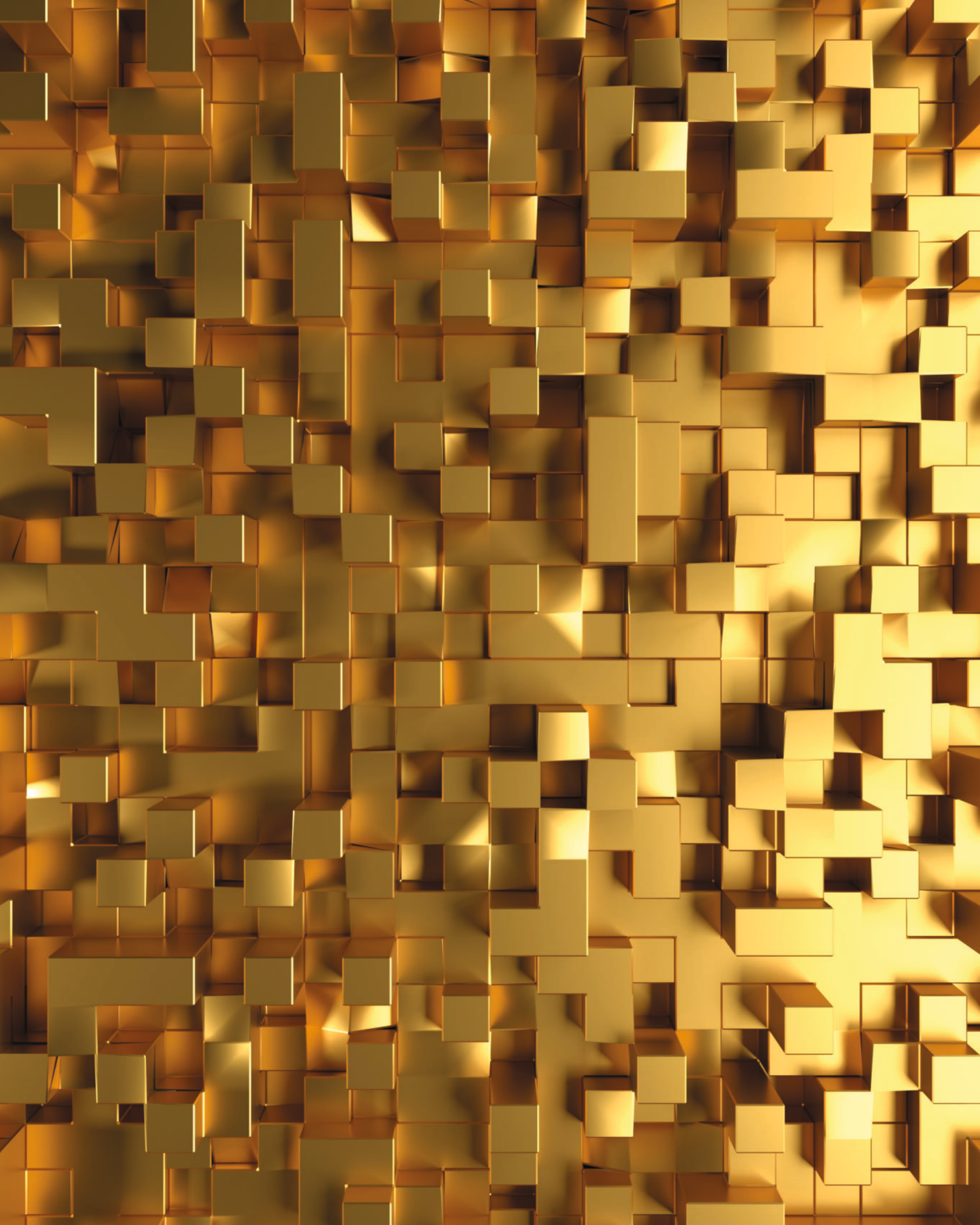

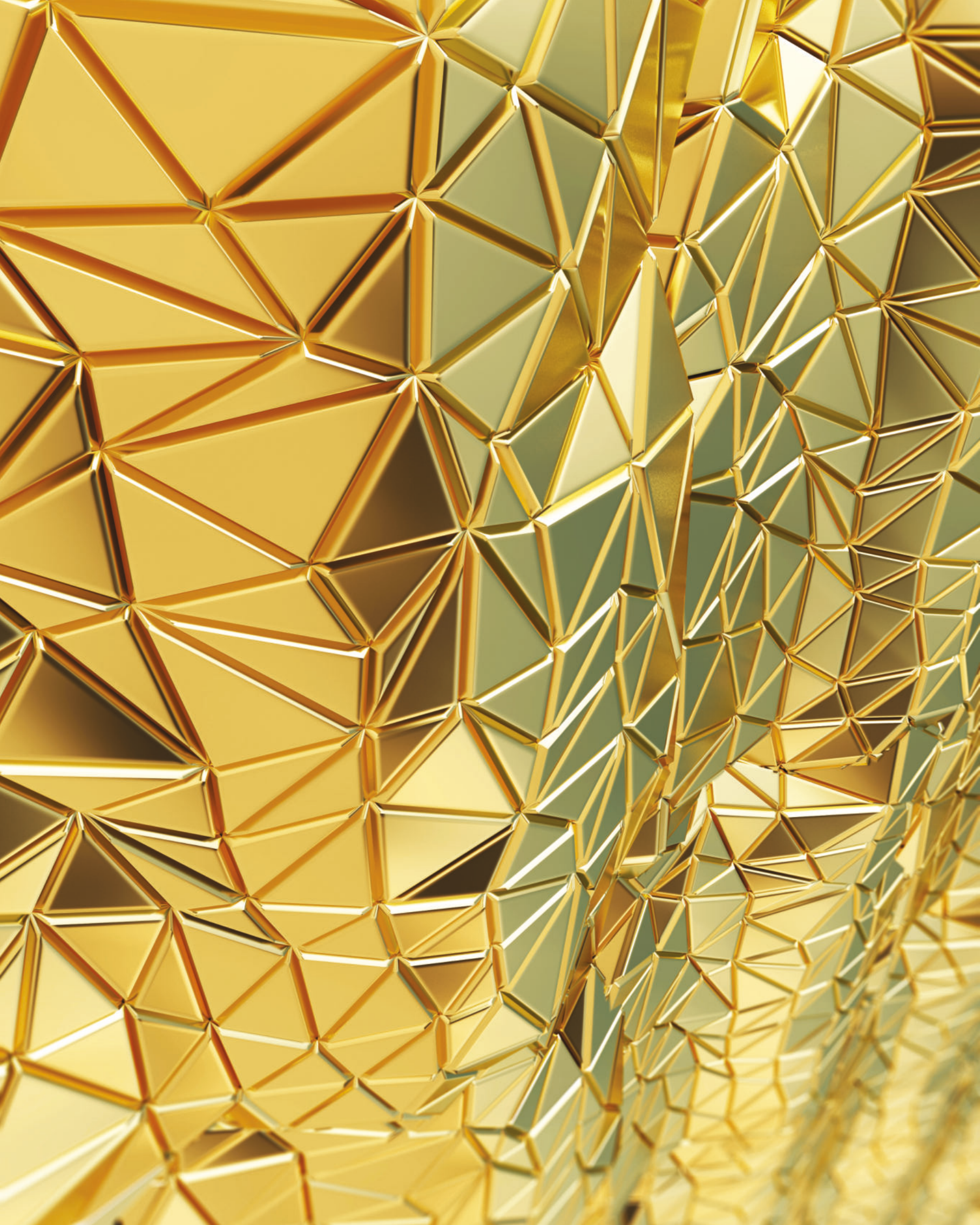

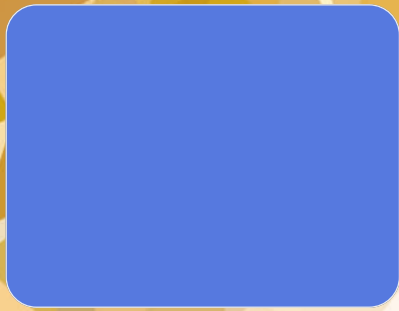

◆ ◆ SB313 | LAKE BLUE



◆ ◆ SB353 | SIGNAL BLUE



◆ ◆ SB333 | NAVY BLUE



◆ ◆ ◆ SB600 | CHOCO BROWN



◆ ◆ ◆ SB212 | JET BLACK



◆ ◆ ◆ SB215 | SLATE GREY

GLOSSY SERIES



◆ ◆ ◆ SB360 | RED GLOSSY

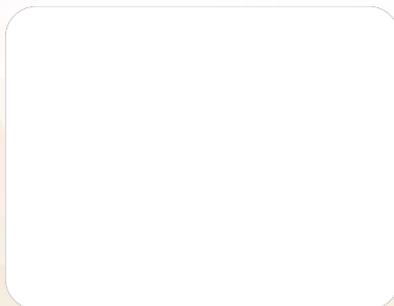

◆ ◆ ◆ SB350 | WHITE GLOSSY



◆ ◆ ◆ SB330 | BLACK GLOSSY



◆ ◆ SB504 | PINK GLOSSY

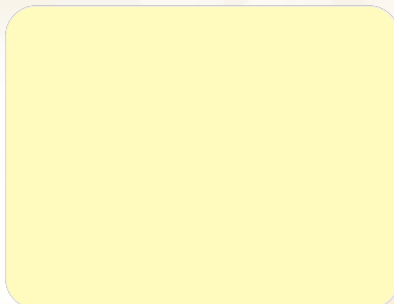

◆ ◆ SB390 | IVORY GLOSSY



◆ SB450 | LIME GREEN GLOSSY

◆ 0.15 MM ◆ 0.20 MM ◆ 0.25 MM ◆ 0.50 MM ◆ 6 MM HPL



SUPERBOND
FUNCTION • QUALITY • DESIGN

METALLIC SERIES

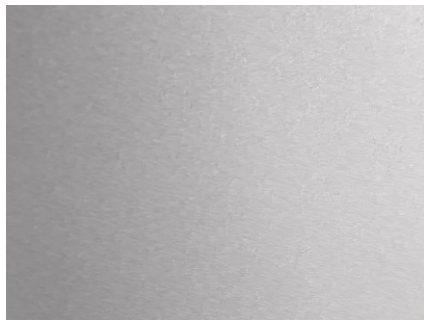

◆◆◆◆ SB132 | SILVER GREY



◆◆◆◆ SB451 | BLACK SILVER



◆◆◆◆ SB133 | FLASH SILVER

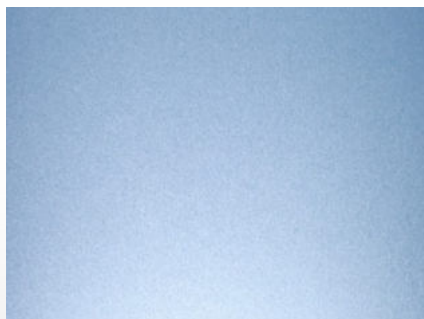

◆◆◆◆ SB251 | METALLIC BLUE

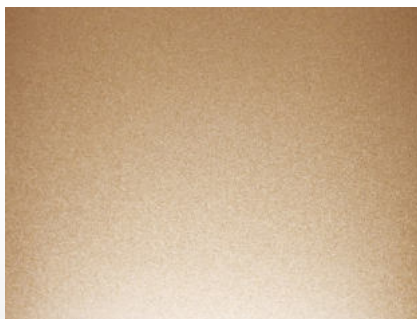

◆◆◆◆ SB213 | PALM COPPER

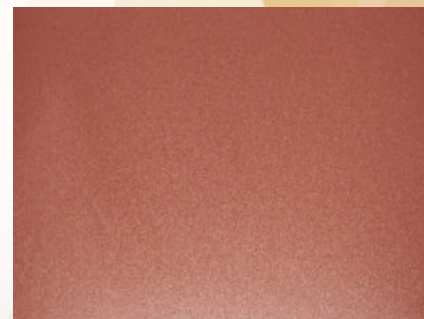

◆◆◆◆ SB326 | PHOENIX COPPER



◆◆◆◆ SB291



◆◆◆◆ SB292 | JADE GREEN

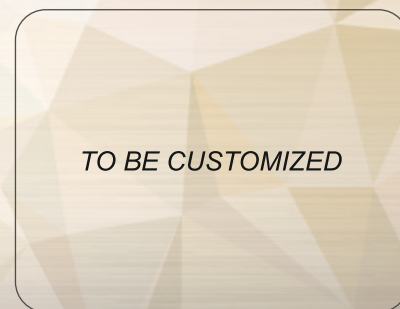

◆◆◆◆ SB293

METALLIC SERIES

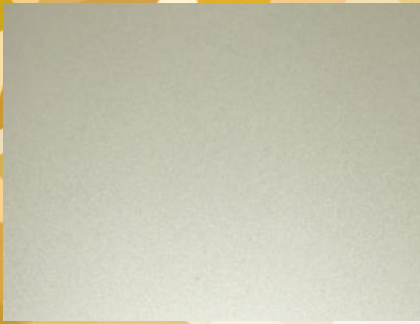

◆◆◆◆ SB122 | CHAMPAGNE SILVER



◆◆◆◆ SB123 | CHAMPAGNE GOLD



◆◆ SB283 | ROSE METALLIC



◆◆◆◆ SB263 | METALLIC GOLD



◆◆◆◆ SB253 | LIGHT BRONZE

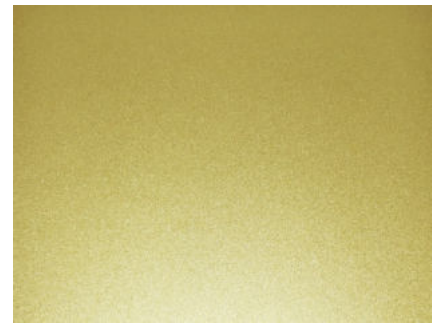

◆◆◆ SB233 | CRYSTAL GOLD



◆◆ SB411 | SILVER BRUSH

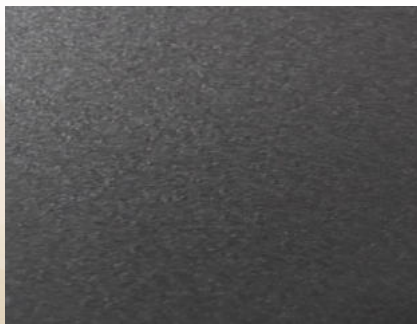

◆◆◆◆ SB010 | DARK GREY METALLIC

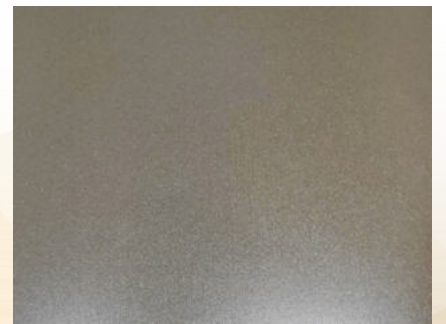

◆◆◆◆ SB273 | METALLIC BRONZE

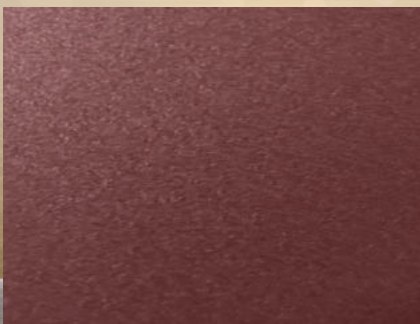

◆◆ SB016 | CHOCO METALLIC

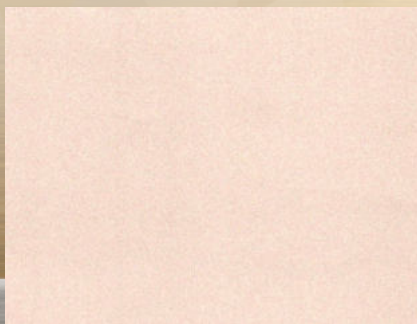

◆◆ SB294 | MAGIC GOLD GLOSSY



TO BE CUSTOMIZED

◆◆ SB018

TIMBER SERIES

Superior wood-like interiors and exteriors are now possible with Super Bond Timber Series. Take your pick from a range of realistic looks and give your designs that extra edge.

These ACPs are super flexible and can bend, fold and turn easily. Straight and angular routing assists in bending the panels to cover angles, clad columns, create linear 'caps' or trays. Beside press brake or pyramid rollers can be used to bend the composite panel into a more desired shape



◆◆ SB901 | BROWN OAK

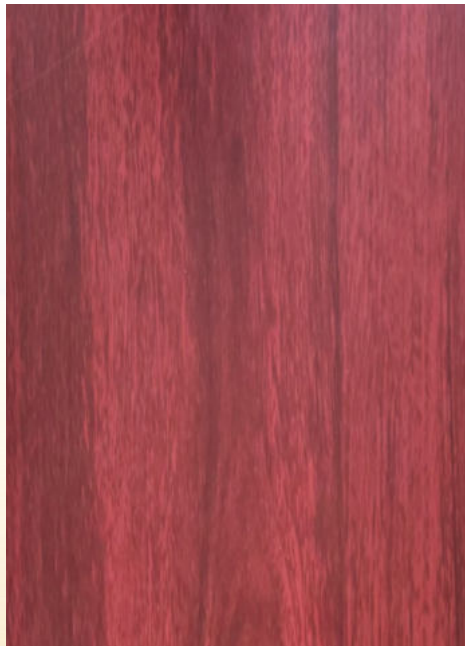

◆◆ SB902 | ROSE WOOD



◆◆ SB907 | GOLDEN CASCADE



◆◆ SB910 | AMERICAN WALNUT



◆◆ SB915 | CANADIAN WALNUT



◆◆ SB905 | BRAZILIAN HULK

TIMBER SERIES



◆◆ SB912 | NATURAL WALNUT



◆◆ SB913 | CREME WALNUT

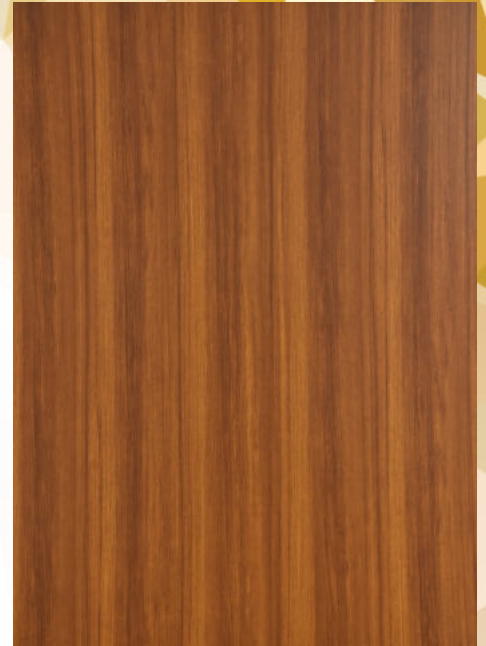

◆◆◆ SB920 | TIMBER WOOD BURMA



◆◆◆ SB906 | SAPHELI

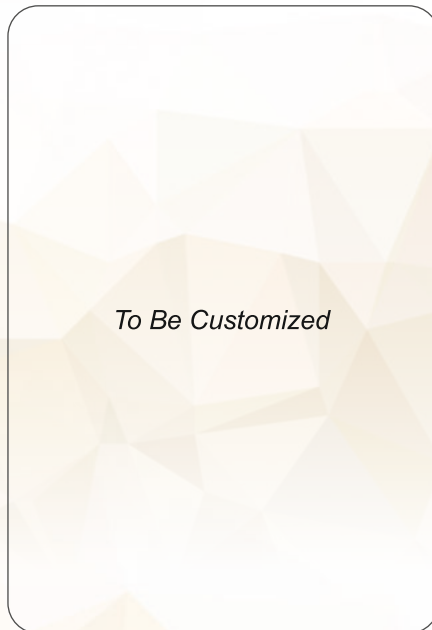

◆◆◆ SB926

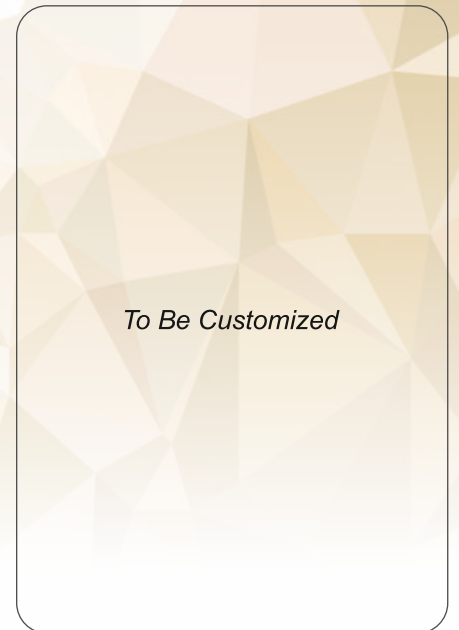

◆◆◆ SB928



TIMBER TEXTURE SERIES



◆ ◆ ◆ SB005 | NATURAL TEAK TX



◆ ◆ SB006 | SMOKE OAK TX



◆ ◆ SB007 | RED OAK TX



◆ ◆ SB008 | BURMESE TEAK TX



◆ ◆ SB621 | AFRICAN EBONY



◆ ◆ SB625 | MAHOGANY PREMIUM

◆ 0.25 MM ◆ 0.50 MM ◆ 6 MM HPL



SUPERBOND
FUNCTION • QUALITY • DESIGN

SAND SERIES

Inspired by nature's pristine beauty

The Sand Series ACP of Super Bond has a natural look and texture without the use of any natural material. Let's add a feel of virgin nature in the world of architecture.

- Suitable for both exteriors and interiors
- Wide range of enchanting shades



◆◆ SD5001 | GREY SAND STONE



◆◆ SD5002 | WHICH BEACH SAND

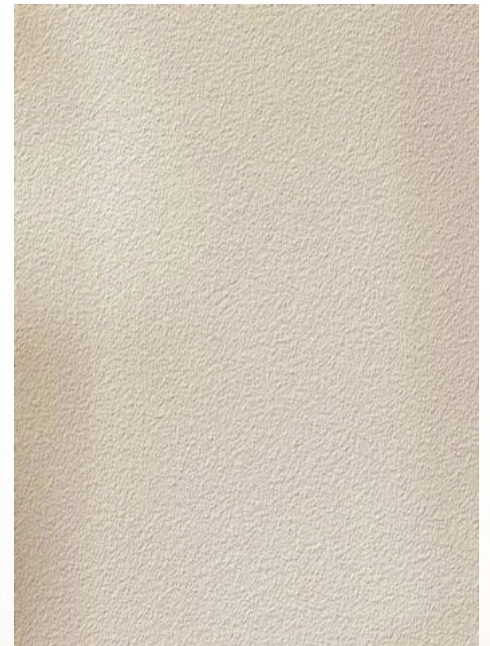

◆◆ SD5003 | ZURICH BEIGE SAND

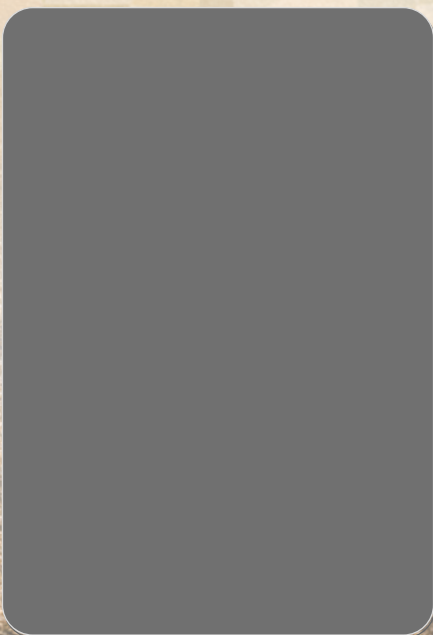

◆◆ SK 4001 | GREY SKIN FEELING



◆◆ SK 4002 | JAISALMER SUNDAY SKIN



◆ SB1010 | TWINKLING STAR

◆ 0.25 MM ◆ 6 MM HPL ◆ 0.15 MM

MARBLE SERIES

MARVEL AT MARBLE

Imagine a warm matte texture that oozes sophistication,
The perfect match for your creation.

With low light reflectivity, the surface is completely opaque and smooth to touch.
The subtle tactile effect accentuates facades greatly.

The dry matte appearance hides dirt and is delightfully easy to Maintain.
Try these attractive, gloss-free finishes to experience the new.



◆ SB801 | TRAVERTINE CREAM



◆ SB804 | EMPERADOR DARK

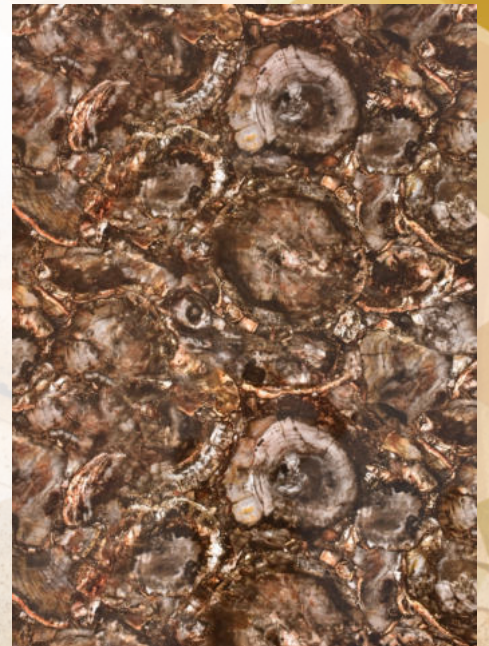

◆ SB821 | BROWN FIRE



To Be Customized

◆ SB840

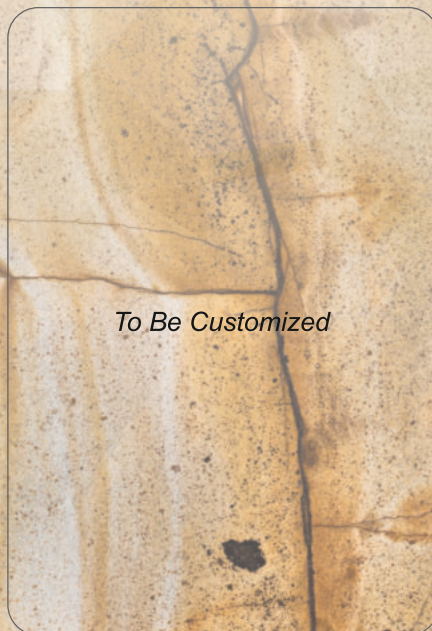

To Be Customized

◆ SB841

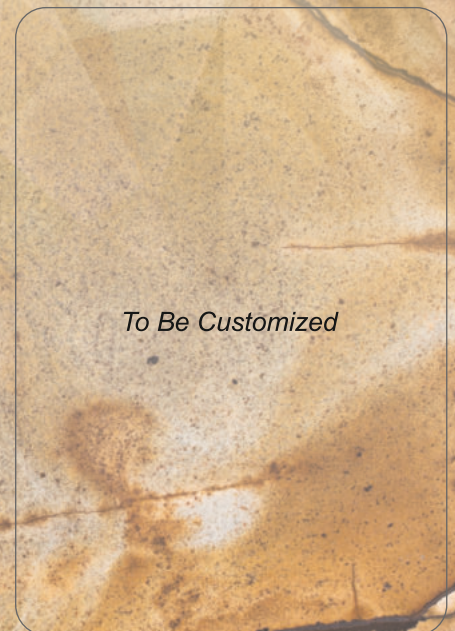

To Be Customized

◆ SB842

MIRROR SERIES

SHINE & STYLE

Super Bond Mirror Series is like no other. It can jazz up interiors and offer wonderful reflections that outshine conventional mirrors. Furthermore it comes with tints that complement your interiors.

Go ahead customise!

#ExcellenceInsideOut



◆◆◆ SB751 | SILVER MIRROR



◆◆◆ SB851 | GOLD MIRROR

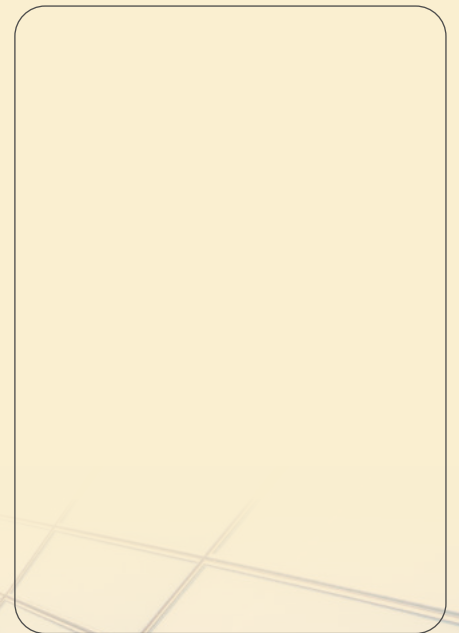

◆ SB551 | STAINLESS STEEL

◆ 0.20 MM ◆ 0.25 MM ◆ 6 MM HPL

SPARKLE SERIES

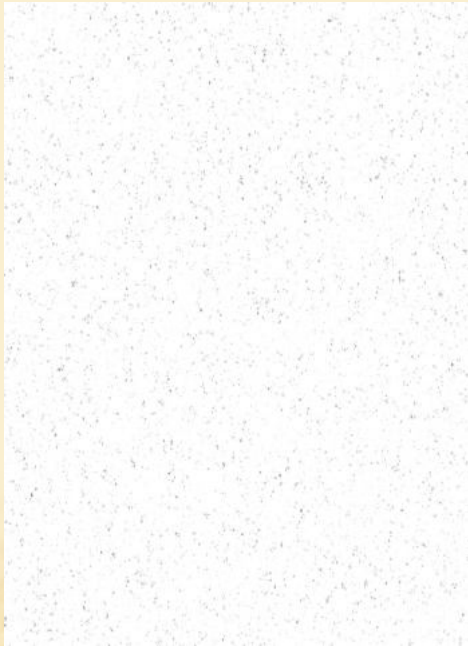

◆◆ SB951 | WHITE SPARKLING



◆ SB981 | CHOCOLATE SPARKLING

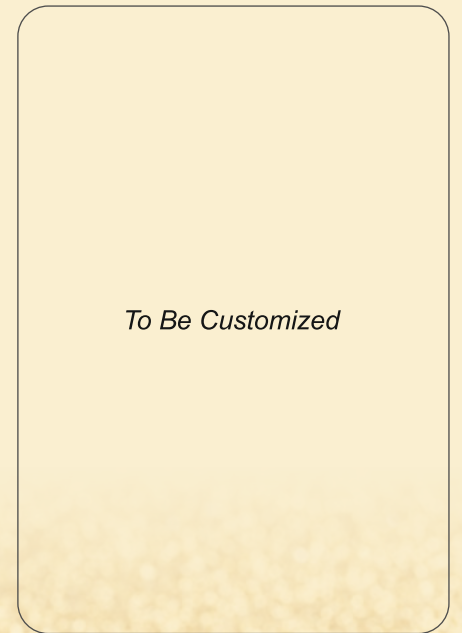

SB921

◆ 0.20 MM ◆ 0.25 MM

PLAIN APP

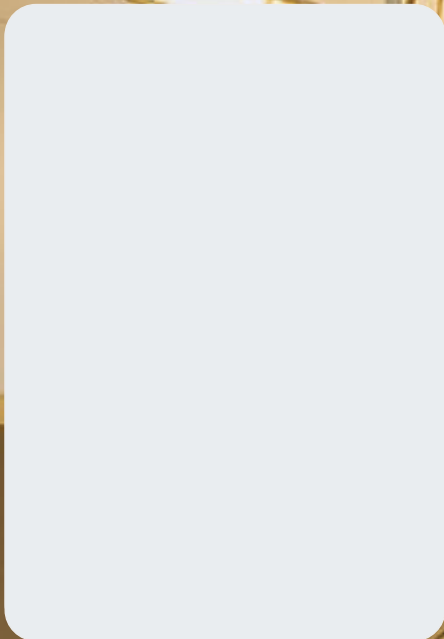

SB131 | BRIGHT WHITE



SB133 | FLASH SILVER

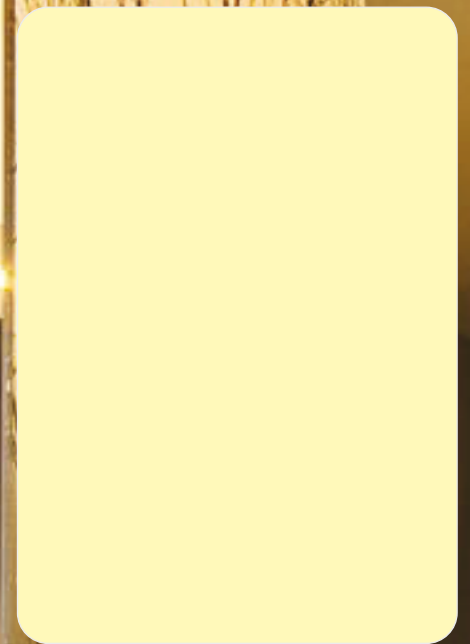

SB113 | IVORY



SB451 | BLACK SILVER



SB600 | CHOCO BROWN



SB233 | CRYSTAL GOLD

Width Options: 915mm & 1220mm
Thickness Options: 3mm, 4mm or custom upto 6mm

PARTITION PANEL SERIES

WOOD APP



SB940 | DARK WALNUT

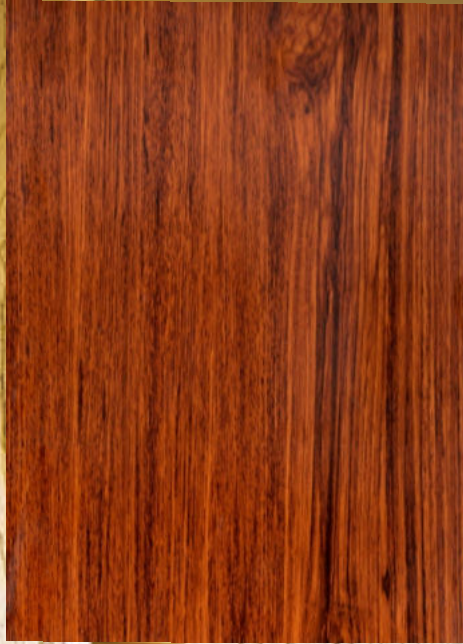

SB930 | MALABAR TEAK



SB915 | ELEGANT TEAK

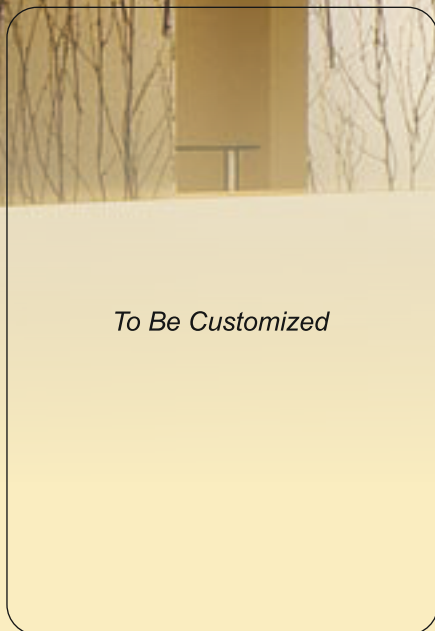

To Be Customized

SB300

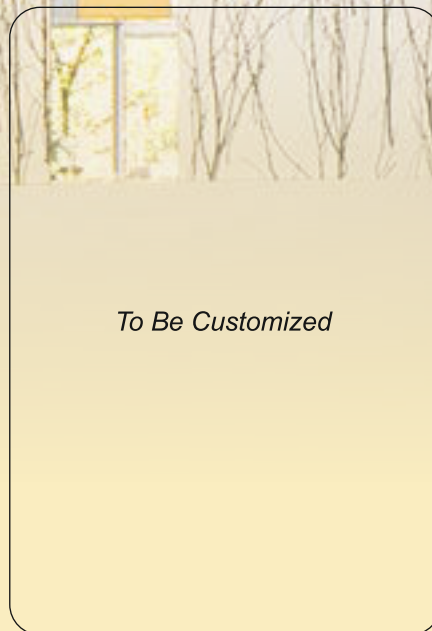

To Be Customized

SB301

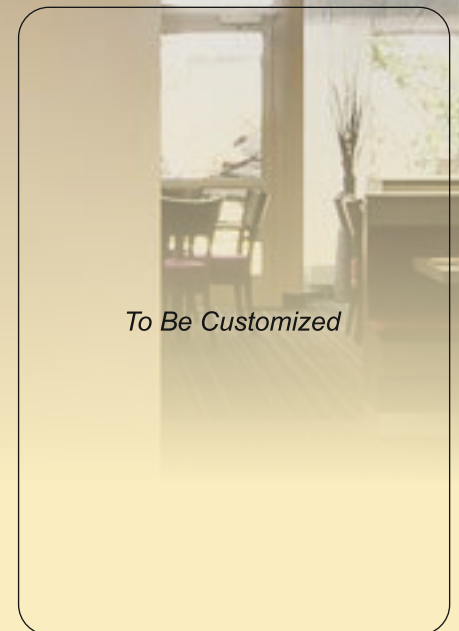

To Be Customized

SB302

- 100% Water proof & maintenance free
- Washable
- Excellent sound and thermal insulations
- Environment Friendly
- Unbreakable
- Light Weight & Rigid

- BFT Guard (Borer, Fungus and Termite Proof)
- Stain resistant
- Reduces labour cost as no polishing required
- Excellent Flatness
- Customised Colors



SUPERBOND
FUNCTION • QUALITY • DESIGN

STONE PATTERN SERIES



STC9067 | FERRARI RED



STC9050 | TWILIGHT BLACK

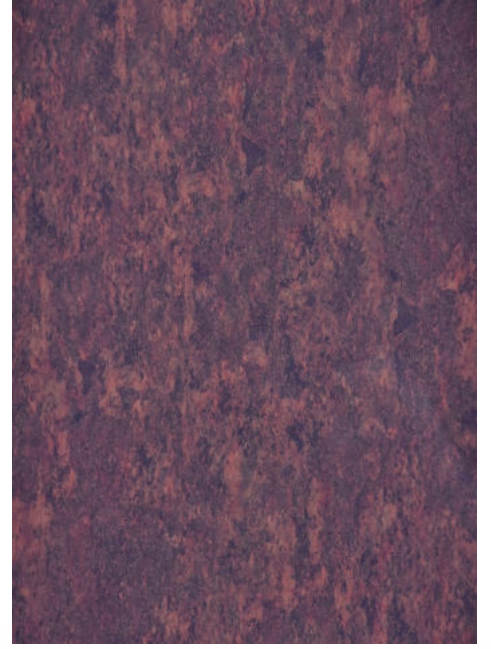

STC9081 | CHARMINAR RED



STC9092 RUSSIAN STONE

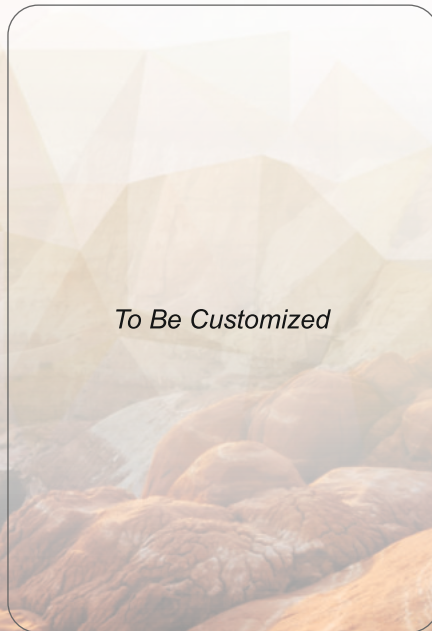

To Be Customized

STC9652



To Be Customized

STC9100



PVDF GOLD SERIES

- 10 year warranty*
- 2 Coat & 2 Bake KYNAR 500 PVDF coating
- Coating thickness 25 to 28 micron
- Custom Colors
- Corrosion resistance
- Durable and Beautiful
- Unbreakable
- Machinable
- Environment friendly
- 100% maintenance free & water proof
- Excellent sound & thermal insulation
- Easy to install
- Resistant to abrasion
- Convex & Concave bending properties
- Stain resistant
- Washable
- Uniform colour

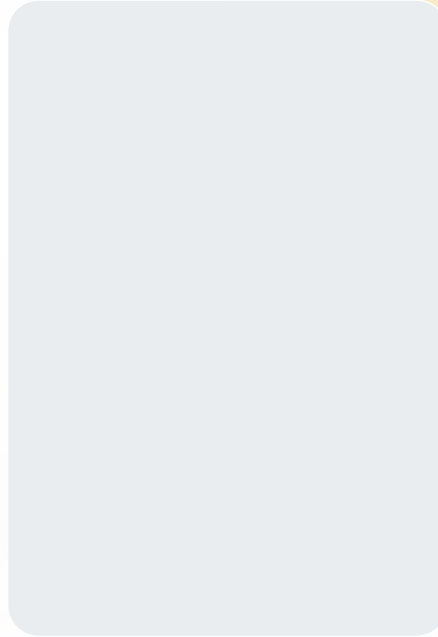

SB131 | BRIGHT WHITE

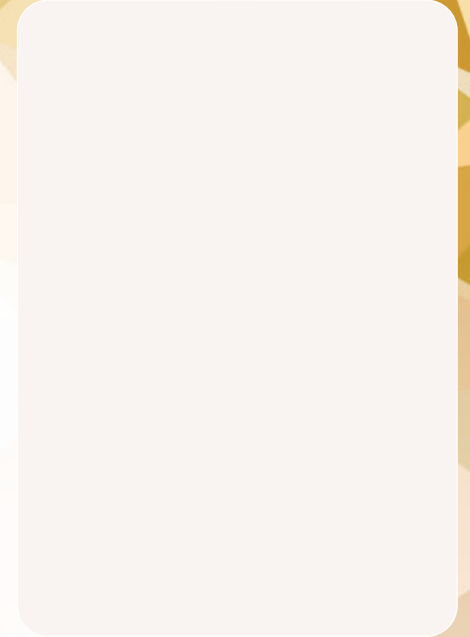

SB503 | MILKY WHITE

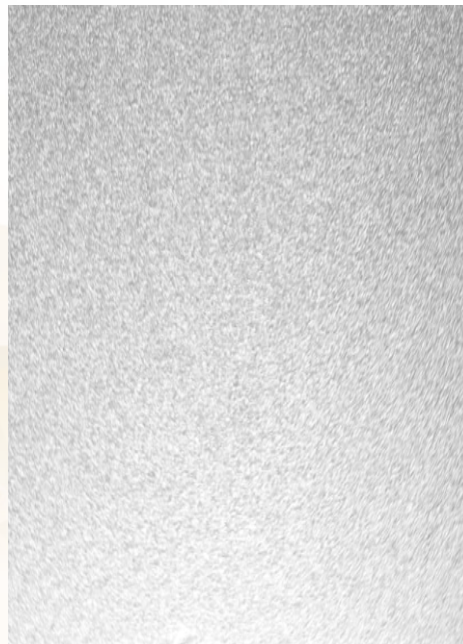

SB133 | FLASH SILVER

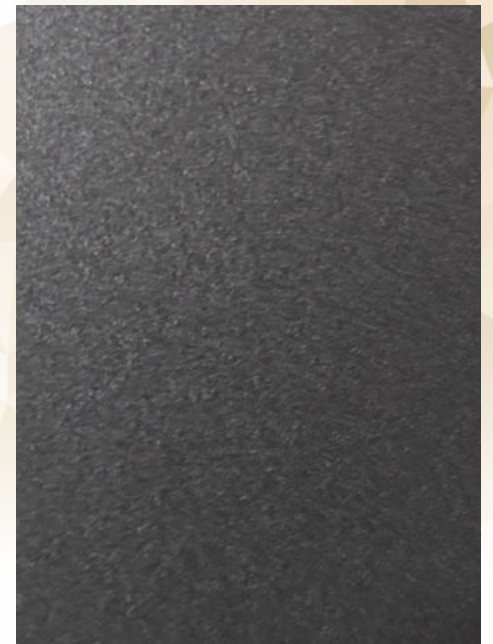

SB010 | DARK GREY METALLIC



FR – ACP SERIES

A real 2-hour escape window

A typical ACP-cladded facade in India has a frame structure comprising a non-load-bearing brick wall, followed by plaster, steel frame and an ACP envelope should contain fire and retain its structural integrity up to 2 hours.

But that's not the only feature that contributes to fire protection. An authentic rating for resistance to fire also takes into account that smoke kills faster than fire, among other vital factors. This is where Super Bond's FR ACP stands above the rest.

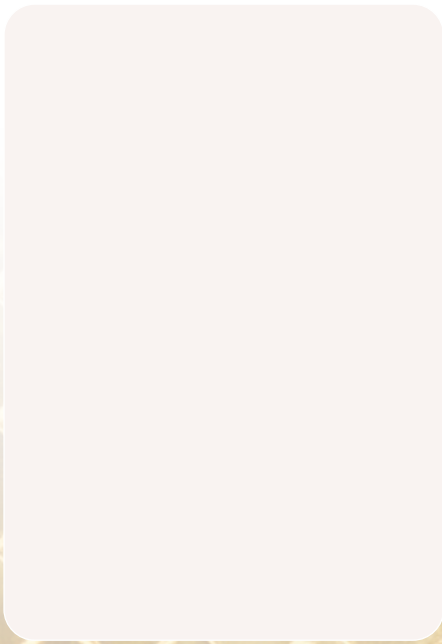

**SB503 | MILKY WHITE
FR GRADE**



**SB010 | DARK GREY METALLIC
FR GRADE**



**SB123 | CHAMPAGNE GOLD
FR GRADE**

◆ 0.5 MM

◆ 0.50 MM

The core secret

FR Core is a non-halogenated FR material that produces water vapor when it heats up. It does not produce toxic gases like the halogenated materials.

Magnesium hydroxide (MDH) is the non-halogenated material that is mixed with PE to form the core of Super Bond's FR products. MDH has a better fire-resistance performance than aluminium trihydrate (ATH), the other non-halogenated material, owing to higher decomposition temperature

Furthermore MDH is more environment-friendly than other similar materials.

MDH delays the PE transformation from solid to plastic (the point of ignition up to 360°C, by releasing water molecules and bringing down the temperature continuously.

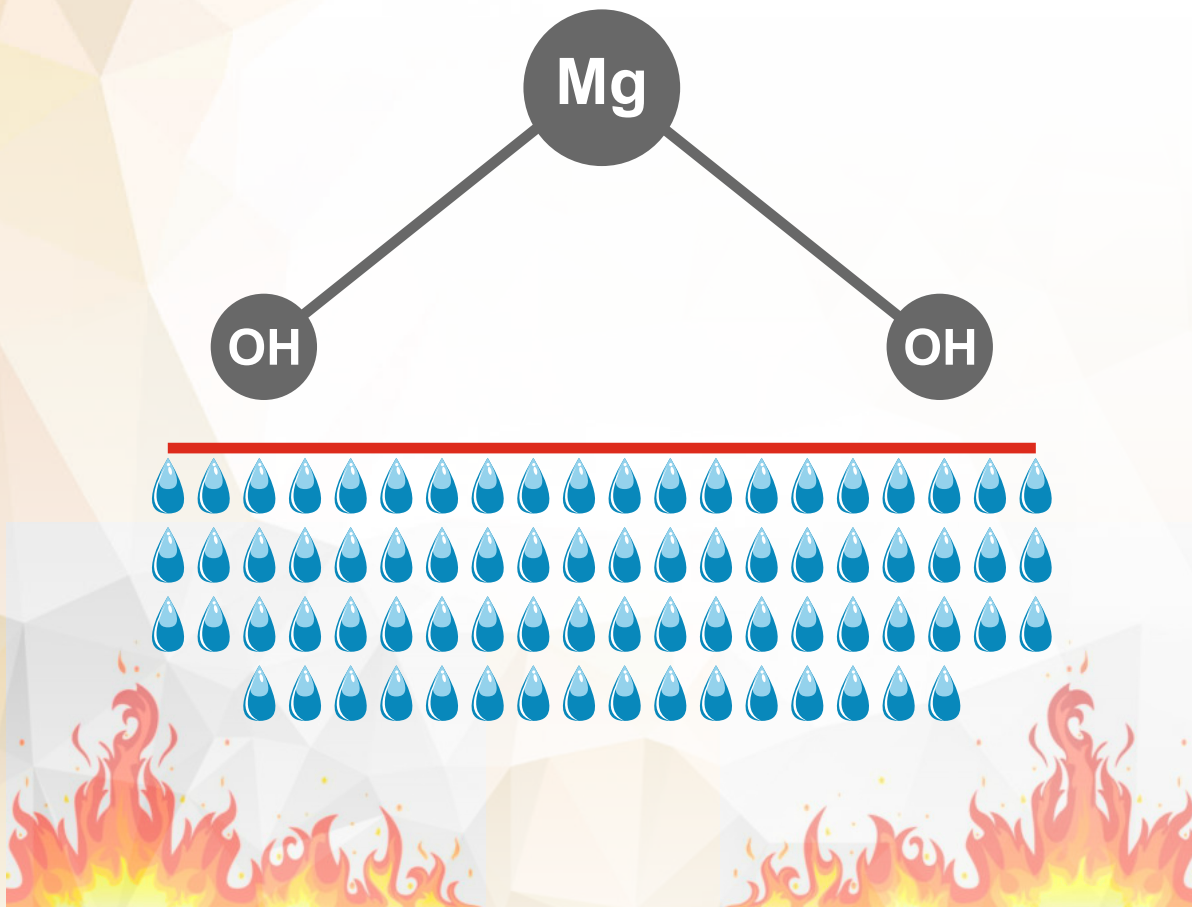

Heated MDH releases water molecules that lower the temperature

Basic chemical reaction of the FR core

Core Details	Polyethylene	Magnesium hydroxide (MDH)	Aluminium trihydrate (ATH)
Chemical reaction	$\text{CH}_2 + \text{O}_2 = \text{CO}_2 + \text{H}_2\text{O}$	$\text{Mg}(\text{OH})_2 = \text{MgO} + \text{H}_2\text{O}$	$2\text{Al}(\text{OH})_3 = \text{Al}_2\text{O}_3 + 3\text{H}_2\text{O}$
Decomposition temperature	90°C to 110°C	310°C to 360°C	190°C to 240°C
Status	Heat generation	Heat absorption	Heat absorption

HPL SERIES

It is here that SUPER BOND brought forward AHPL, which is an Aluminium based High Pressure Laminate (HPL). It is more durable and elegant in looks as compared to wood. It is also highly weather resistant. AHPL has overcome the shortcomings of wood as it is manufactured using aluminium coil with double layered Lumiflon coating that is resistant to dust. It has a polyethylene core that makes it resistant to water, fungus and termite.

To top it all Super Bond HPL comes in a variety of colors, texture and sizes. SUPER BOND also offers customized colors and sizes. AHPL has redefined the concept of high-end facade and exterior. SUPER BOND offers professional service as it has a robust marketing network in India and abroad. Whether it is Villas, Housing Societies, Corporate Buildings or Resorts, AHPL is a perfect foil in place of wood.

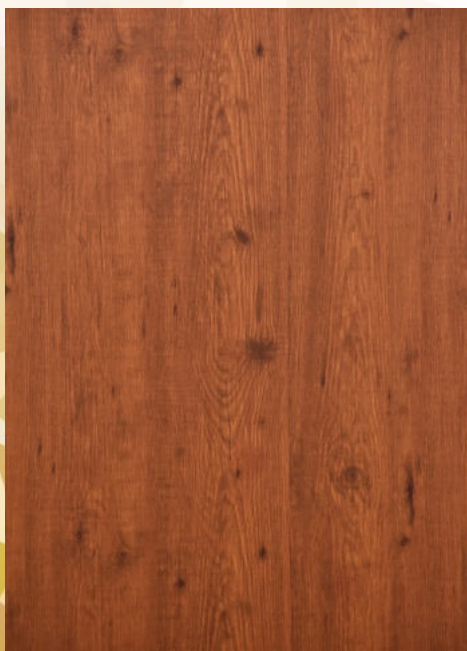
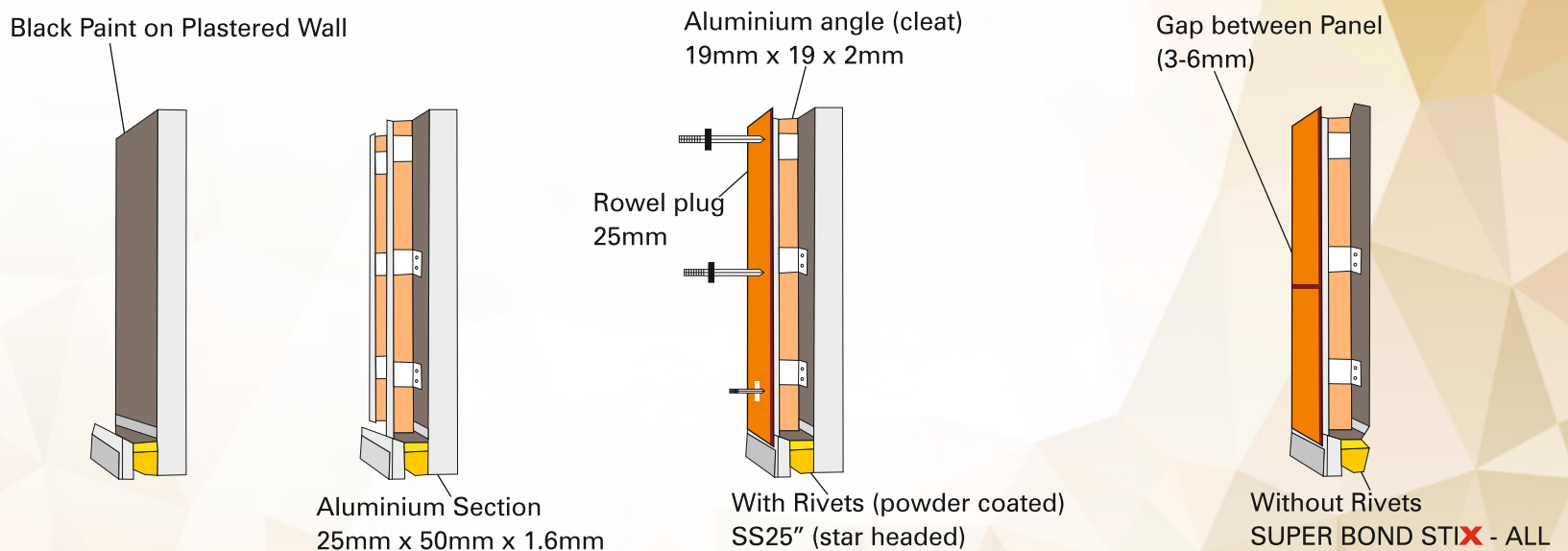

SB920 | TIMER WOOD BURMA

Fixing Detail (with Rivets)

- Black Paint on Plastered Wall
- Fix aluminium section on wall, maintain gap of 400 - 700mm center with help of cleat vertically
- Pilot hole must be pre-drilled before fastening rivets tight.
- Size of rivets must be three times the thickness of panel and gouge of aluminium. Ensure rivets used are fully threaded.

NOTE: ALL WOOD SERIES SOLID, METALLIC COLOR CODES CAN BE MADE IN HPL

◆ 6 MM HPL & ◆ 8 MM HPL SERIES



REDUCE REUSE RECYCLE



SUPERBOND[®]
FUNCTION • QUALITY • DESIGN

Head Office: 17, Super House, Amar Brass Industrial Estate, Kalina CST Road,
Near Raheja Centre Point, Santacruz East, Mumbai - 400 098

Factory Address: Keybond Industries LLP, Plot No. 6, 7 & 17, 18, Amgaon Industrial
Estate, Village Amgaon, Taluka Talasri, Palghar, Maharashtra - 401 606

Email: superbond@superbondindia.co.in • **Web:** www.superbondindia.co.in

Factory Email: keybondindia@gmail.com



10* Years Warranty

All Super Bond products are a landmark in durability and quality. Our stringent quality checks ensure that our products are free from any manufacturing defects. However, we recommended that you inspect the products prior to installation.

Increase of any issues with product quality, we are liable for the cost of our product only. Complete details regarding the warranty terms are available with our authorized dealers.

* Not applicable in Interior Grade.

